



ETROVISION

Model: **EV6552AP**

**Ergonomic Design VGA Indoor dome with
POE Compatability**



Special Features:

- 90° Pan, 10° Tilt Adjustable
- 1/4" Sensitive CMOS
- 3.6 mm Fixed Lens ; 0.5 Lux
- Day and Night ; DIP Switch
- H.264, MPEG-4, M-JPEG Dual Streams
Simultaneously
- VGA, QVGA, QQVGA Image Resolution
- Up to 30fps at VGA Resolution
- 2-way Audio ; Digital In / Out
- Power over Ethernet (EV6552AP)
- DIP switch mirror image
- UP to 20 sec Video Buffer
- Female RJ-45 Ethernet 10Base/100 Base TX
- File/Clip Upload via FTP and Email, Notification
via Email, External Output Activation

The Etrovision EV6552AP internal IP dome camera provides a stylish architecture design to meet the criteria of any modern building standards. The low profile is discreet with a small footprint, while still offering VGA resolution. The unit provides two way audio and digital I/O, for complete interfacing to access controls, intercom and alarm systems.

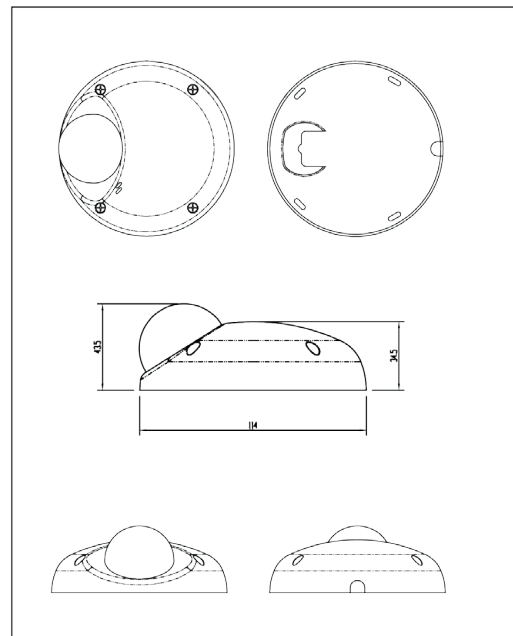



ETROVISION

Model: EV6552AP

Ergonomic Design VGA Indoor dome with POE Compatability



CAMERA	Image Sensor	1/4 Low-Light Sensitive CMOS
	Lens	3.6mm Fixed Lens
	Light Sensitivity	0.5 Lux
	Shutter Time	1/30~1/50,000
	Camera Angle Adjustment	Pan / Tilt / Rotation
	Pan / Tilt / Zoom	Pan: 0~90 / Tilt: +/-10 / Rotation+/-10
	Number of Effective Pixels (HxV)	640 x 480
	Gain	Adjustable
	White Balance	Adjustable
	Sync System	Internal
	Resolution	640 X 480 VGA
	S/N Ratio	38dB

System Integration & Maintenance	Application Programming Interface	EtroSDK 3.0
	Intelligent Video	Video Motion Detection
	Alarm Events	Intelligent Video, File Upload via FTP and E-mail, Notification via E-mail, External Output Activation
	Video Buffer	Pre-and Post Alarm Buffer up to 10-sec
	Configuration	EtroScan Utility
	Web Browser	Microsoft Internet Explorer 6.0, or Above

Video / Audio	Video Compression	M-JPEG, MPEG-4,H.264 Format Selectable
	Resolutions	VGA(640x480), QVGA(320x240), QQVGA(160x120)
	Frame Rate	Up to 30fps@ VGA Resolution
	Video Streaming	Simultaneous Dual Stream Controllable Frame Rate and Bandwidth
	Image Settings	Compression, Brightness, Contrast, Exposure Control, White Balance ,
	Bit Rate	M-JPEG: 5 Video Quality Level Selectable; MPEG-4/H.264 : 64K~4Mbps
	Audio	Audio In/Out : ADPCM

General	Casing	Molded PVC
	Dimension	114() X 39(H) mm
	Processor and Memory	ARM9 Base SoC, 128MB RAM, 16MB Flash
	Power	12V DC / 1A
	Connectors	RJ-45 for 10BASE-T/100 BASE-TX,DC Jack ,EtroLink , Video Out, Audio Out, DI/DO
	Operating Conditions	Temperature: 0 C ~ 40 C (32 F ~ 104 F)
		Humidity: 20% ~ 80% RH
	Power over Ethernet	Yes
	Approvals	CE, FCC, RoHS, ctick
	Weight	330g
Included Accessories	Power Adapter, USB Cable, CD-ROM (User Manual, Free Bundle NVR), Video Out Cable	

Network	Security	Password Protection, IP Address Filtering, User Access Privelge
	Supported Protocols	TCP/IP, DHCP, PPPoE, HTTP, DDNS, NTP, FTP, SMTP, UDP, RTSP, 3GPP, UPnP